

GAS HOT WATER

Domain Continuous Flow Gas Water Heater - 25L/min

- **Maximum 6 STAR Gas Rating**
- **Freeze prevention device**
- **Standard 240v power supply**
- Rated for environmental temperatures down to -15°C
- Digital wall mounted control (option)
- Low greenhouse emissions
- Low running costs
- High efficiency
- Quality design and manufacturing
- Compact design
- Flexible installation
- Excellent sales support
- Ideal for two to three bathroom homes

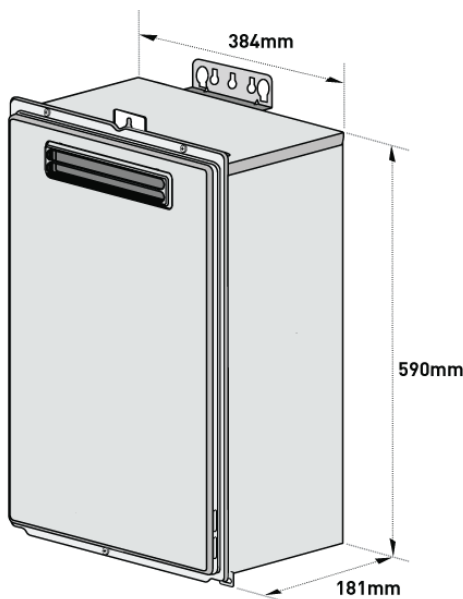

Domain model		GHI-26
Capacity	L / Minute	25
Gas Output	MJ / h	180
Inlet Supply Pressure - Natural Gas	kPa	1.13
Water Supply Pressure	kPa	150* min.
Height	mm	590
Depth	mm	181
Width	mm	384
Weight	kg	20
Ignition	-	Electronic
Electrical Supply Voltage	AC	240V
Operating Current	Amps	0.9

* The water heater will operate at reduced performance when inlet water supply pressures are below 340kPa.